



CRUMB REMOVAL DRUM

CASA HERRERA'S MOTORIZED DRUM-PRE-FILTER OPERATES BETWEEN THE FRYER AND MAIN OIL PUMP. THIS UNIT REMOVES LARGE PARTIALS FROM THE FRYER BEFORE IT REACHES THE MAIN FILTER CANISTER UNITS. THIS SYSTEM INSURES LONGER FILTRATION CYCLES BETWEEN THE MAIN FILTRATION CANISTERS.

PRODUCT FEATURES

- *Stainless steel housing, covers, mesh filter, connections, and support frame.*
- *Rotating mesh filtration drum assembly*
- *Filter Mesh designed for easy cleaning and maintenance.*
- *Continuous particle removal waste conveyor*
- *Stainless Steel Steam exhaust vent.*
- *Hinged Doors for easy access and cleaning*
- *Large inlet and outlet ports for continuous oil flow.*



FOR MORE INFORMATION CALL 800.624.3916

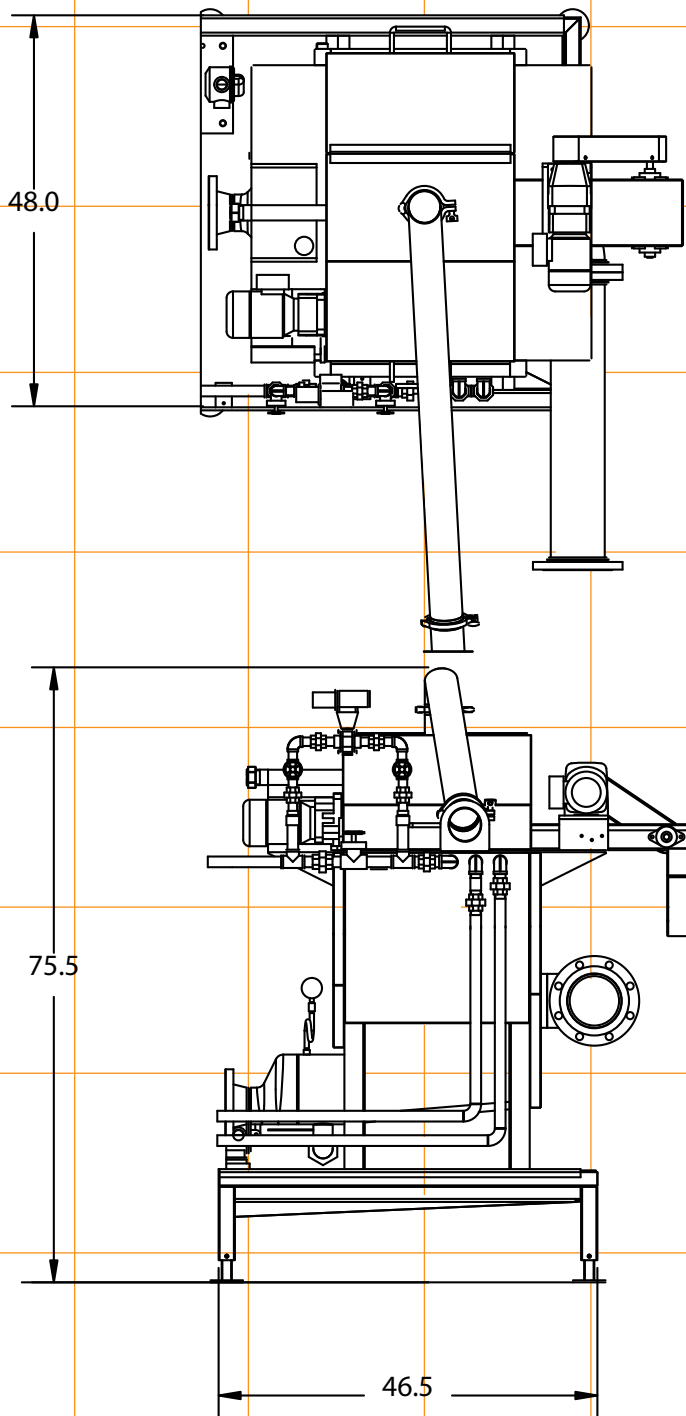

CRUMB REMOVAL
DRUM

*We are constantly working
to develop and improve our
products to better serve
your growing needs.*



2655 NORTH PINE STREET, POMONA, CALIFORNIA 91767
TELEPHONE: 909.392.3930 FAX: 909.392.0231

WWW.CASAHERRERA.COM