

PALS PRESS AUTOMATIC LOADER SYSTEM

THE NEWEST SOPHISTICATED SYSTEM FOR PROOFING, PRESSING AND LOADING OF DOUGHBALLS.
THIS EQUIPMENT IS DESIGNED TO SAVE LABOR COSTS AND PRODUCE FLOUR TORTILLAS AND
VARIOUS FLAT BREADS WITH MORE UNIFORM QUALITY.

PRODUCT FEATURES

- *Doughballs are automatically placed in predesignated spots*
- *Gentle pre-pressing prevents movement of doughballs, enabling speedier operation*
- *Constructed of non-corrosive stainless steel and ultra-high molecular plastic*
- *Tubes have internal teflon coating*
- *Angle of tube and 1 piston per tube insures precise dough placement*
- *Advanced feature: Retractable frame deesign allows clearance of the doughballs to travel in main frame*
- *All cylinders are pneumatically operated and utilize a pneumatic manifold*
- *Constructed on a tubular frame which can be easily removed and stored in a special protective rack.*
- *Includes humidifier and multi-zone system*
- *PAL Systems are available in multi-configuration patterns from 4-drop to 16-drop depending on desired tortilla size*

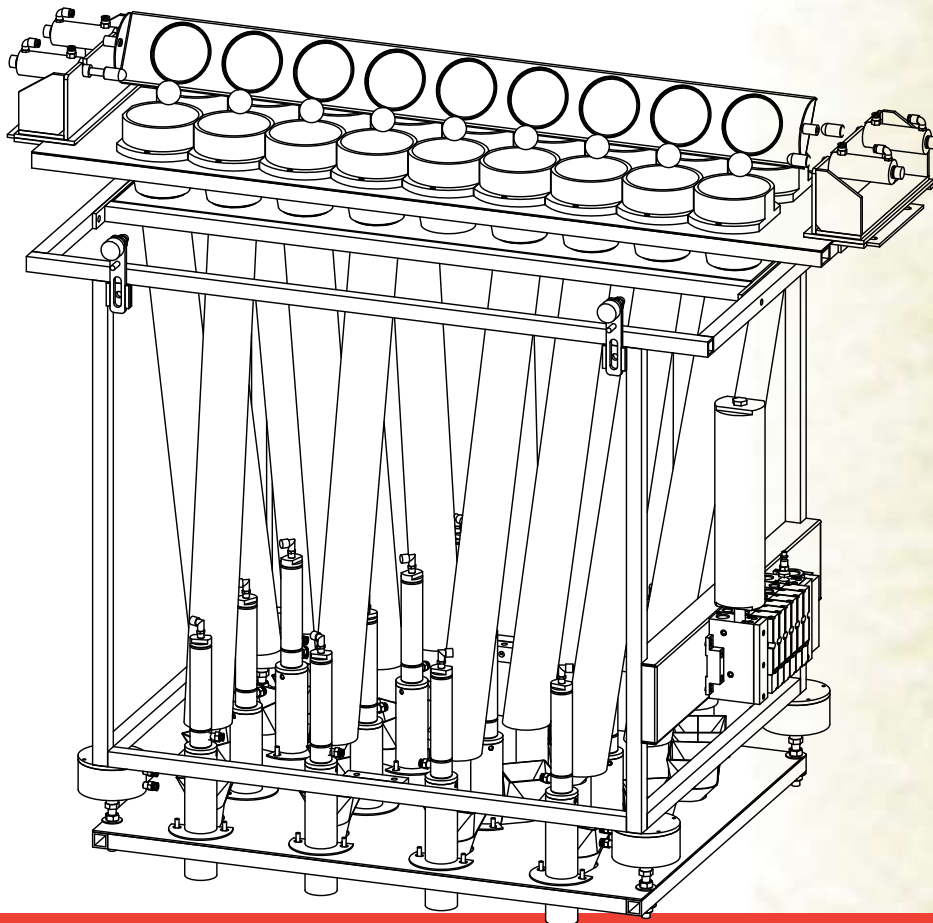

FOR MORE INFORMATION CALL 800.624.3916

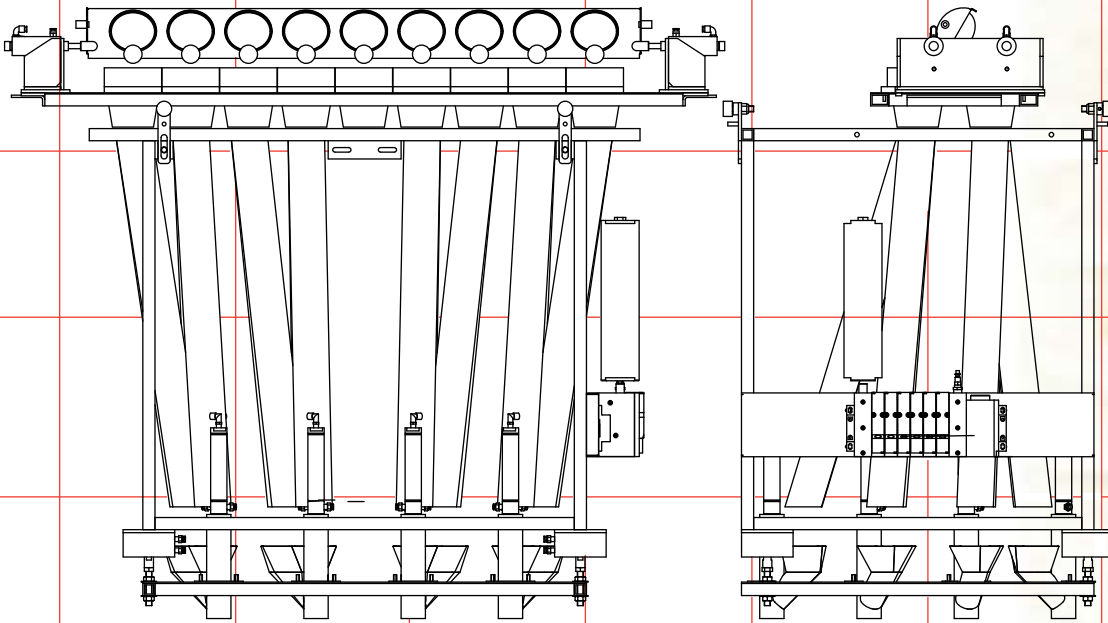
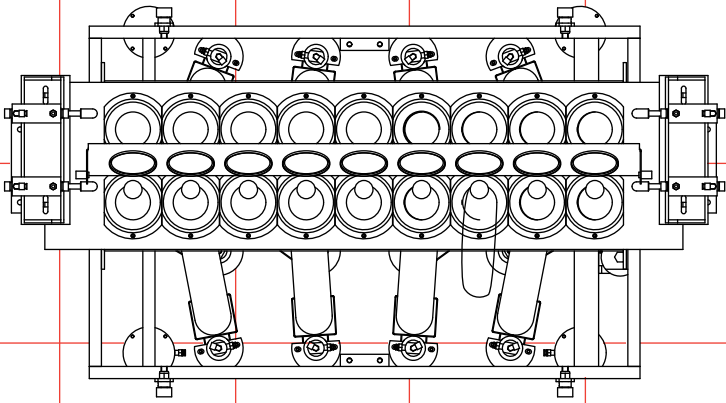

CASA HERRERA
MANUFACTURERS OF FOOD MACHINERY

2655 NORTH PINE STREET, POMONA, CALIFORNIA 91767
TELEPHONE: 909.392.3930 FAX: 909.392.023

WWW.CASAHERRERA.COM